

# trak<sup>®</sup> Xchange MU

manual battery handling unit  
for battery changes  
in the battery room



## Motive Power Systems

Reserve Power Systems

Special Power Systems

Service

## Your benefits:

- **Minimal effort required** – manual changing facilitated by use of gearing
- **Flexible use** – suitable for vehicles with different battery changing heights
- **Easy and safe to operate** – battery change directly by the truck driver
- **Cost-saving solution** – just one person needed for battery changing
- **High level of safety** – locking system ensures safe transfer

## Typical applications

- Vehicle fleets (one changer for up to 10 vehicles)
- Preferred battery sizes  
24 V to 80 V
- Centralised and decentralised battery rooms



## trak<sup>®</sup> Xchange MU

Complete battery changing process in less than 6 minutes

The trak<sup>®</sup> Xchange MU manual changer is suitable in conjunction with a hand pallet lift truck for users dealing with batteries weighing up to 750 kg, or for batteries up to 2500 kg when an electric lift truck is used.

Both vehicle types offer a height-adjustable lifting mechanism, which makes the system suitable for all vehicles with side extraction. trak<sup>®</sup> Xchange MU has a gearing which reduces the amount of effort needed for battery changes. The locking system ensures safe transfer of the battery.

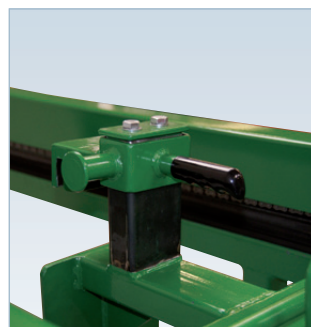
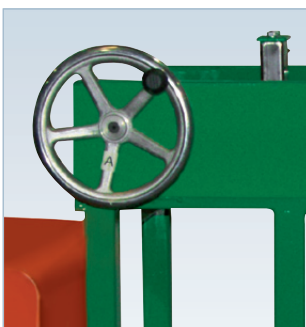
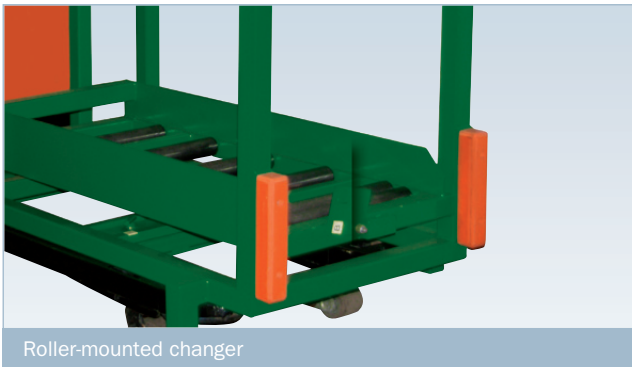

	trak <sup>®</sup> Xchange	MU
Industrial truck	Preferred fleet size	From 1 truck upwards, different models
	Preferred number of spare batteries per changer	10
	Preferred types of truck	Reach trucks Counterbalance trucks Tow trucks
	Battery compartment with roller bed	✓ <sup>(1)</sup>
	Battery compartment with slide rails	✓ <sup>(2)</sup>
Battery	Preferred battery type	24 V - 80 V
	max battery dimensions (LxWxH), models for different battery sizes	1250x1000x800
	Battery weight (max. in kg)	2500 <sup>(1)</sup> /1500 <sup>(2)</sup>
Features	Battery removal means	Clamping hook with crank and Continuous chain
	Battery bed	Simple roller bed
	Structure/support vehicle	Manual or electric pallet truck
	Height adjustment	Lifting truck
	Height adjustment range (mm)	Ca. 120mm (lift of the support vehicle)
	min./max. changing height (mm)	145 - 400
	Compensation for tyre wear	✓
	Space required in the system	Medium
	Effort needed for changing	Minimal
	Time taken to change a battery	Ca. 6 min.